

High-Level Number Multilevel Single-Phase Current-Source Inverter With Reduced Switching Device Count

Eka R Priandana^{1,2,4}, Toshihiko Noguchi^{3,5}

¹Environment and Energy System, Graduate School of Science and Technology, Shizuoka University, Hamamatsu, Japan

²National Laboratory for Energy Conversion Technology (B2TKE) of Agency for The Assessment and Application of Technology (BPPT), Tangerang Selatan, Indonesia.

³Department of Engineering, Graduate School of Integrated Science and Technology, Shizuoka University, Hamamatsu, Japan.

⁴eka.rakhman.priandana.17@shizuoka.ac.jp

⁵noguchi.toshihiko@shizuoka.ac.jp

Abstract. This paper proposes an advanced technique in generating a pure sinusoidal output current waveform for the high number multilevel single-phase current-source inverter (CSI) with reduced switching device count. Previous multilevel CSI development proposed a new technique in generating pure sinusoidal output by compensating the staircase current with a linear current. This linear current compensation intends to reduce the output filter capacitor size without sacrificing inverter efficiency. However, this hybrid multilevel CSI would give higher efficiency and performance if applied in high number of levels. Consequently, the system needs high switching device count. Too many switching devices utilization will decrease the performance and the power density of the CSI as well. Therefore, this technique is introduced and only possible to be realized if the number of levels is higher than 5-level. By applying multilayer stage method while managing the DC current module activation sequences, the high number of levels CSI can be constructed with only using few DC current modules. As a result, according to the computer comparison simulation, the implementation of the proposed technique delivers relatively equal results compared to the conventional one just by utilizing fewer switching devices.

1. Introduction

A multilevel inverter is a power electronic device that is capable of providing desired AC voltage level at the output using multiple lower-level DC voltages as input. In the voltage topology, there are mainly three different types of the multilevel inverter: 1). Diode clamped, 2). Flying capacitor, and 3). Cascaded H-bridge [1][2]. However, this kind of multilevel inverters will encounter a problem while supplying heavy inductive loads such as AC motors. The multilevel voltage-source inverter (VSI) does not have robust self-protection against the short circuit load as well as having high dv/dt and di/dt transient behaviors.

On the other hand, the multilevel current-source inverter (CSI) is less applied due to the main disadvantages: high conduction losses and low power density. The highest efficiency can be achieved if the multilevel CSI supplies the heavy load with high number of levels. Nevertheless, its advantage such as having natural protection from short circuit and low dv/dt or di/dt cannot be omitted.



Therefore, the further multilevel CSI development is still needed in to provide an alternative solution in power electronics [3].

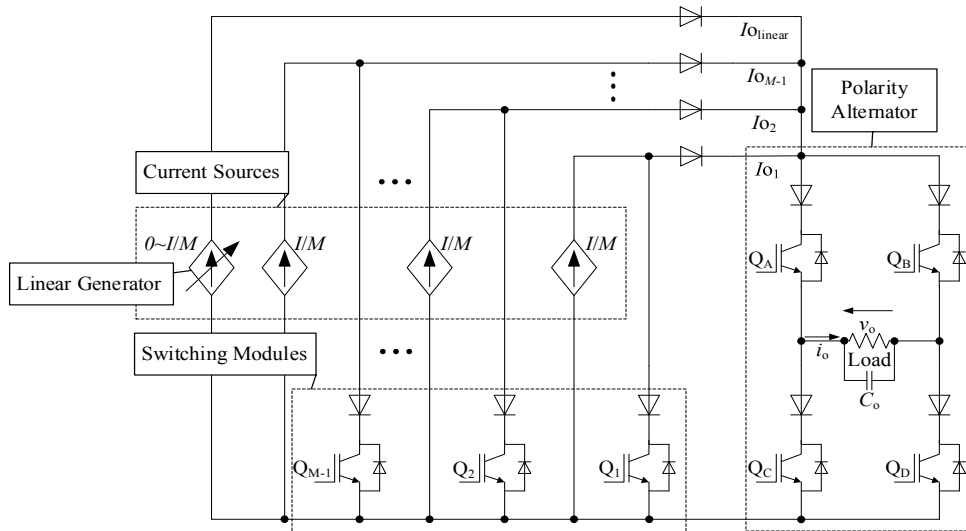

Figure 1. Generalized concept of hybrid multilevel CSI.

This paper discusses new development of the multilevel CSI with multiple DC current source type as a dual circuit of the multilevel VSI. Recently, authors [4–8] have reported a new concept of a hybrid multilevel CSI by incorporating stair case current wave form generator with a linear current wave form generator as described in figure 1. However, this linear current generator has very poor power efficiency [9]. Therefore, to reduce the losses significantly, a very a high number of levels must be applied, so that the required linear compensation current amplitude can be generated as small as possible.

The problem occurs when applying a high number of levels because the switching device count linearly conforms to the number of levels. Too many utilizing the switching device will not reduce the losses significantly and instead it will decrease the power density. Therefore, a new technique for controlling and switching the devices to generate pure sinusoidal current output with high number of levels by using fewer switching devices is proposed in this paper. Hence, the power density may be improved without sacrificing the power quality and power efficiency of the system.

This paper is composed as follows: first, the operation principle and the circuit configuration of the multilevel CSI are introduced. Next, the control and switching strategies are proposed. In order to evaluate and compare the fundamental operation, several multilevel CSI operations are demonstrated by computer simulations. From the simulation results, it is possible to generate pure sinusoidal current output with a high number of levels using fewer switching devices.

2. Operation principle and circuit configuration

Firstly, the basic operation principle and the circuit configuration of the multilevel CSI are introduced in this section.

2.1. Operation principle

As described in figure 1, the hybrid multilevel CSI consists of constant current sources, a linear current source, switching modules, and a polarity converter (or inverter) that represented by an H-bridge circuit. In order to simplify the circuit from the viewpoint of current generation and power source configuration, a circuit diagram in figure 2 is presented. The DC current module block consists

of a buck chopper-based constant current source and a switching module. Basically, the number of CSI levels is expressed by:

$$N_{level} = 2M + 1 \tag{1}$$

The M represents the number of total DC current modules and linear current generator that used in a multilevel CSI system. Figure 3 illustrates the basic operation principle of the hybrid multilevel CSI.

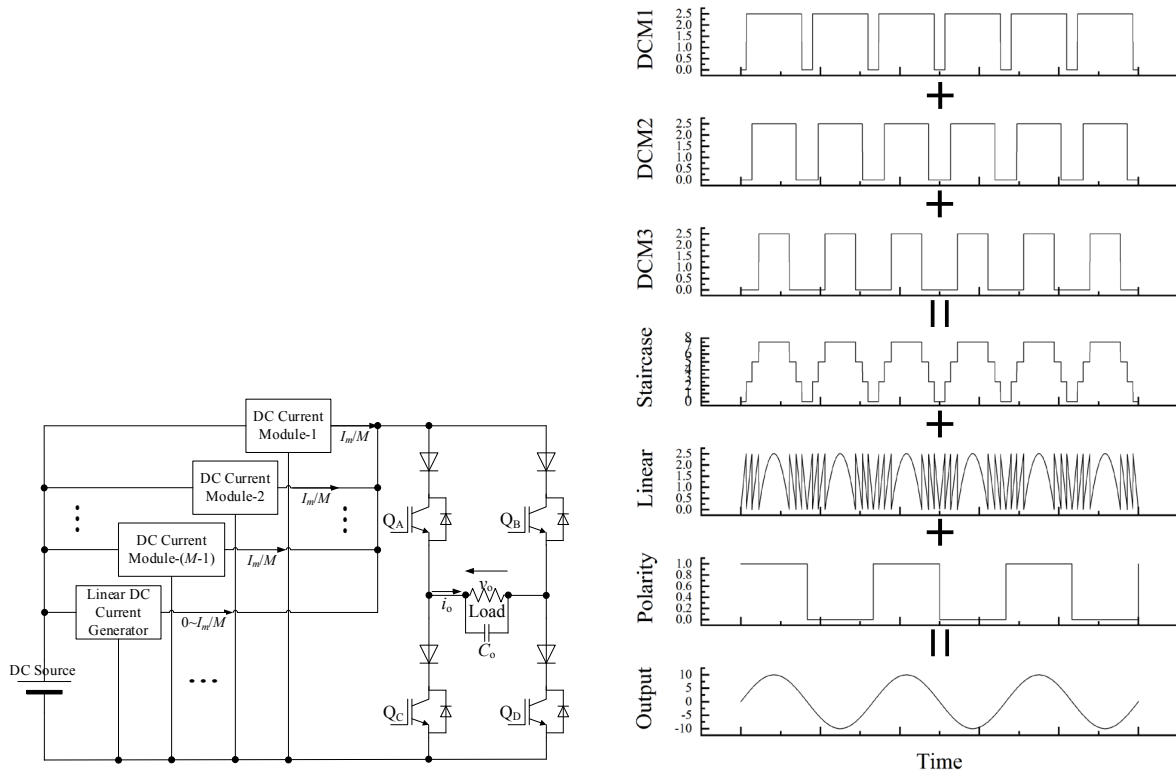

Figure 2. Overview circuit configuration.

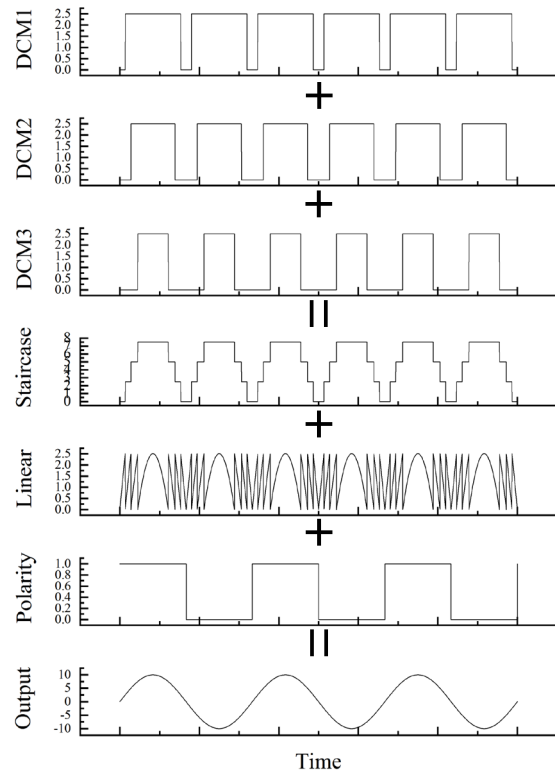

Figure 3. Basic operation principle of the 9-level hybrid multilevel CSI.

For this instance, the operation of 9-level CSI with 20 Amperes peak-to-peak is presented. In the case of 9-level CSI, by using equation (1) the number of required DC current modules is four. The first three modules are used for generating staircase current waveform, meanwhile the remaining one is required for generating linear current waveform. After all generated currents are summed up in a DC link node, a H-bridge is utilized to alternate the polarity of the current whenever the zero-crossing of the reference is detected. Due to linear current utilization as compensator, a small output capacitor is required for smoothing the waveform from high-frequency very-low amplitude ripples.

2.2. DC current module

A DC current source can be generated from DC voltage buck regulator. In order to compact the circuit, the buck chopper circuit is combined with the switching module part. This merged circuit is called DC current module as depicted in figure 4. The operation principle of this circuit is explained in table 1 [4]. The buck chopper circuit consists of a controlled switch Q1, a smoothing inductor L, and a freewheeling diode D1. The Q1 is used for converting the voltage source to a current source by regulating the DC current flowing through the L. To reduce the smoothing inductor size L, a high switching frequency PWM operation is applied.

The D1 is used to keep continuous current flowing through the L. The switching module part consists of a controlled switch Q2 and two reverse-blocking diodes D2 and D3. The Q2 directs the current from

the I_L whether flowing forward to the load or circulating back to the chopper. The switching module part works based on the comparison between the absolute value of the sinusoidal reference with the current limit of each source. Therefore, this part is driven by low switching frequency operation.

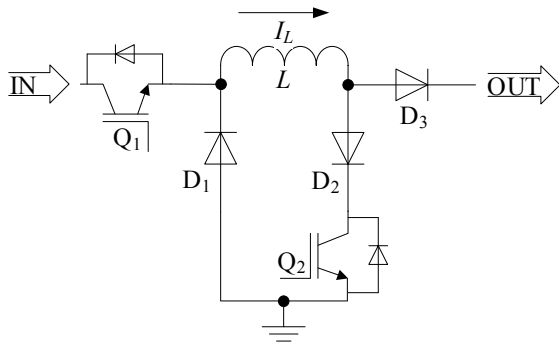

Figure 4. DC current module.

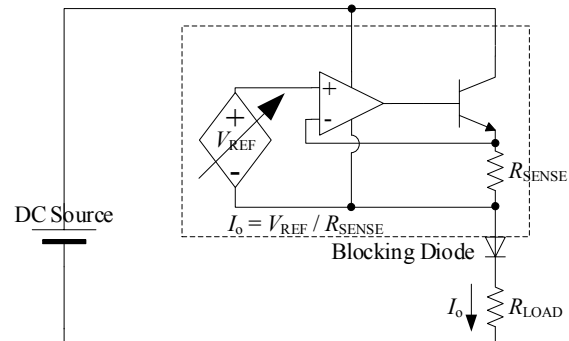

Figure 5. Linear current generator.

Table 1. DC current module operation principle.

Q1	Q2	Output
0	X	0
Switching	0	I_L
X	1	0

2.3. Linear current generator circuit

The key feature of this multilevel CSI development is applying linear circuit as the current compensator. The output current from this circuit is superimposed onto staircase current in order to reshape the waveform into pure sinusoidal. As shown in figure 5, the linear current generator is constructed from class-A amplifier with emitter-follower configuration [10]. In spite of giving better output THD results, this circuit has an extreme low power efficiency. Therefore, in order to apply this circuit, the generated current must be minimized as low as possible. And the only way to do is increasing the number of levels of the multilevel CSI.

3. Proposed control and switching strategies

In order to increase the number of levels without adding more switching devices, the basic operation of figure 3 needs to be modified. As shown in figure 2, each DC current module must have equal current reference I_{REF} and limit which are determined by the main controller as shown in figure 6. On the other hand, the proposed method enables the reference and limit of each DC current module are not necessarily equal. The simplest way to apply this method is by making the current reference and limit of the next DC current module is half of the previous one as shown in figure 7. The first DC current module is set to generate a half of I_{REF} , meanwhile the next module is set to generate a half of the previous one. This process is repeated until the last utilized module.

Because of this arrangement, a multilayer stage of staircase current waveform generation is formed. It means there is a smaller staircase current waveform inside the larger one as described in figure 8. The largest staircase current waveform is referred as the first layer or the outmost layer. In case of hybrid multilevel CSI, the last layer is the linear current compensator. Except the last one, each layer may contain one or more DC current modules that depends on the design requirements.

In case of figure 7, each layer contains one DC current module. This arrangement allows the DC current module-1 (DCM-1) to generate the current amplitude two times compared to the conventional

method. DCM-2 generates an equal rating but with three times switching frequency. And DCM 3 generates the current with a half of the conventional method but with seven times switching frequency. Figure 9 shows the operation changes that occur as a result of implementing this method. This proposed method also affects the linear compensator current. It generates a half compared to the conventional method. Due to smaller amperage, the losses that dissipated by the linear circuit should be reduced.

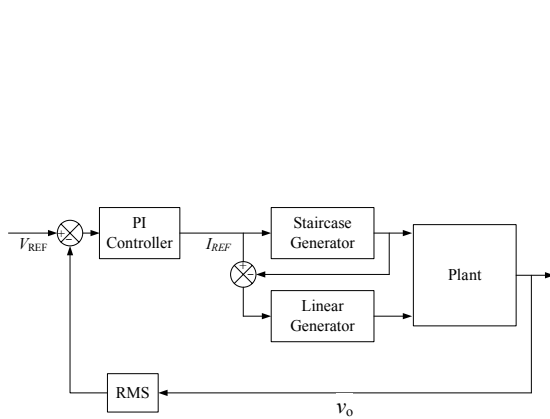

Figure 6. Main controller.

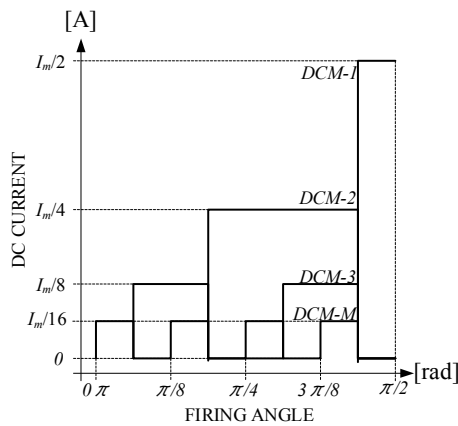

Figure 8. Multilayer stage of staircase current.

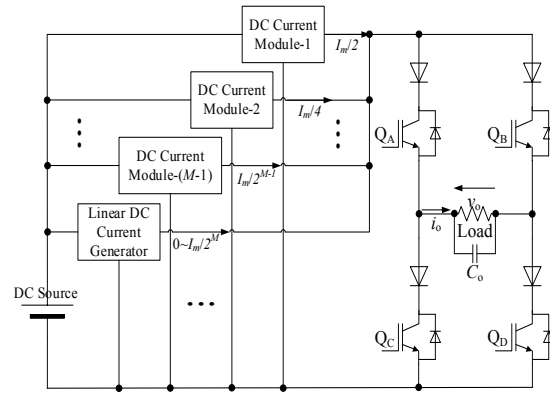

Figure 7. Simplified proposed method.

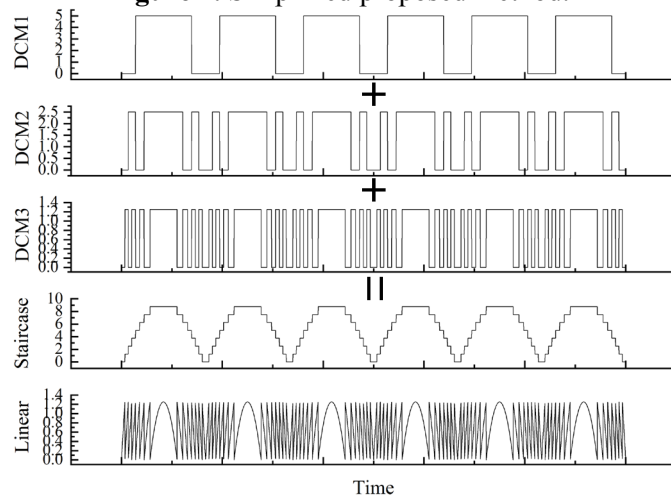

Figure 9. Proposed staircase current generation.

Table 2. Possible combination multilevel CSI with 4 current modules ($M = 4$).

Combination	Number of Layers	Number of Levels
3 – 1	2	9
2 – 1 – 1	3	13
1 – 2 – 1	3	13
1 – 1 – 1 – 1	4	17

Regarding to figure 7 arrangement, the possible maximum number of levels can be determined as:

$$N'_{level(MAX)} = 2^M + 1 \tag{2}$$

It is inferred the equation (2) enables the system by using only four current sources or module ($M = 4$) can generate the multilevel current up to 17 levels.

3.1. Multilayer stage combination

As mentioned above, the arrangement is not necessarily following the equation (2) which one layer is performed by one DC current module. In case of high rating current application, it will be difficult to be done because the first DC current module must employ a large smoothing inductor. Therefore, one layer of staircase generator may be performed by more than one module. For instance, the given system is with four DC current modules.

The possible combination to construct a multilevel CSI is shown in table 2. The first combination with 2 layers is referred as the conventional method because it follows the equation (1). The following combinations with 3 layers are presented as alternative methods to increase the number of levels of the CSI. The last combination with 4 layers is referred to case of figure 7 and it follows the equation (2) to construct a CSI with the highest number of levels.

The number of levels can be calculated from such combination by this procedure:

1. Firstly, the number of layer and the possible combination are determined.
2. The combination consists of head number that refers to outmost layer, body numbers that refer to inner layers, and the tail number that refers to the last layer and this is always one.

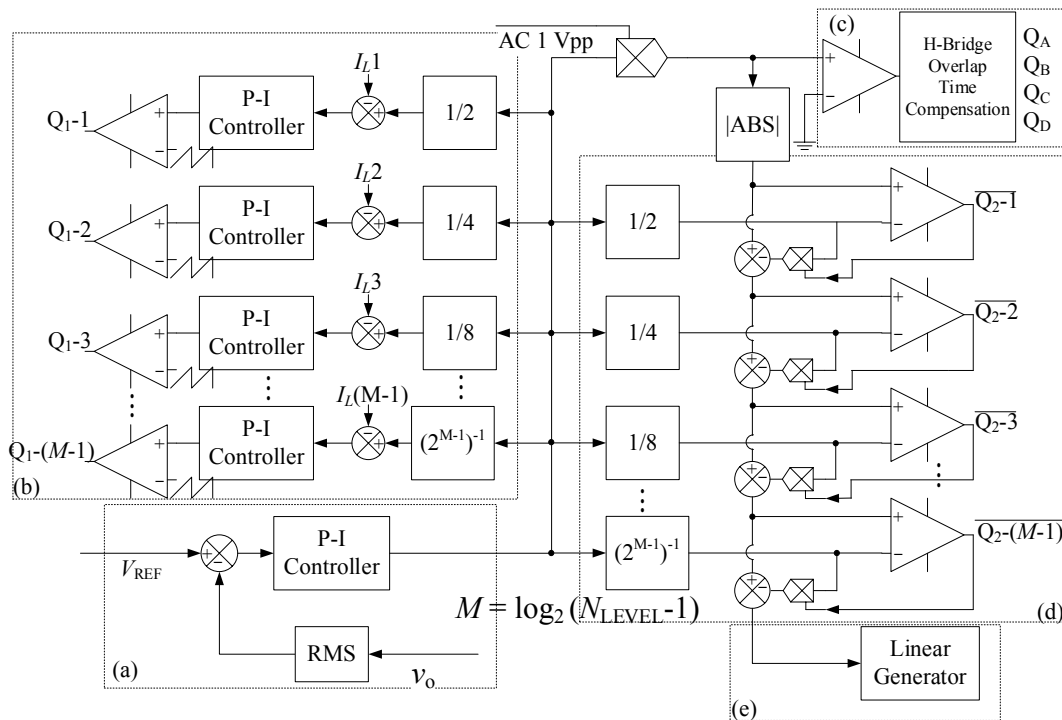

Figure 10. Complete control system for the proposed method.

3. The head number and body numbers represent the number of stages which equals to the corresponding number plus one. For example, if the head/body number is 4, then the number of stages is 5.
4. All the number of stages that represented by the head and body numbers are multiplied and accumulated. The tail number is neglected.
5. Equation (1) is then used to calculate the final number of levels.
6. For instance, the given combination of 10 current modules with 4 layers is 4-3-2-1. The head is 4 that represents 5 stages. The first body is 3 that represents 4 stages. And the second body is 2 that represents 3 stages. Hence, the number of levels that constructed from this combination is $[2 \times (5 \times 4 \times 3)] + 1 = 121$ -level.

3.2. Overview control system

Figure 10 describes the complete control system for the proposed method that conforms to the circuit diagram in figure 7. Technically, this control scheme is divided into five sections, they are: (a) load voltage controller, (b) buck chopper current controller, (c) polarity inverter, (d) staircase current waveform generator, and (e) linear current wave form generator.

4. Simulation results

In order to verify the proper operation of the proposed method, the multilevel CSI with four DC current modules ($M = 4$) and with multilayer stage combination that listed in table 2 are tested and compared by using simulation application PSIM. Prior to the simulation, several parameters are determined as listed in table 3.

Figure 12 is the simulation result of the conventional 9-level CSI with stage combination 3-1 in two layers. Figure 13 is the simulation result of 13-level CSI with stage combination 2-1-1 in three layers. Figure 14 is the simulation result of 13-level CSI with stage combination 1-2-1 in three layers. And figure 15 is the simulation result of 17-level CSI with stage combination 1-1-1-1 in four layers.

Four figures show minor differences on the AC output. The obvious differences are the staircase and linear currents as well as the DC current waveforms. The critical differences can only be presented in quantity measurements such as total harmonic distortion (THD) and power efficiency.

Table 3. Simulation parameters.

Parameter	Value	Parameter	Value
DC voltage	200 V	DCM blocking diode	1.0 V/20 mΩ
Inductor	560 uH/0.09 Ω	Bridge blocking diode	1.0 V/12.5 mΩ
Filter capacitor	2.2 uF/1 mΩ	BJT hFE gain	1000
Load	5 Ω/1 mH	BJT bias/ V_{CE} sat	5.0 V/1.0 V
DCM IGBT V_{CE}/R_{CE} ON	1.4 V/20 mΩ	Sense resistor	1 Ω
DCM IGBT V_D/R_D	1.0 V/20 mΩ	Operational amplifier	Ideal
Bridge IGBT V_{CE}/R_{CE} ON	1.8 V/20 mΩ	Sawtooth frequency	30 kHz
Bridge IGBT V_D/R_D	1.2 V/20 mΩ	Output voltage	100 V/60 Hz

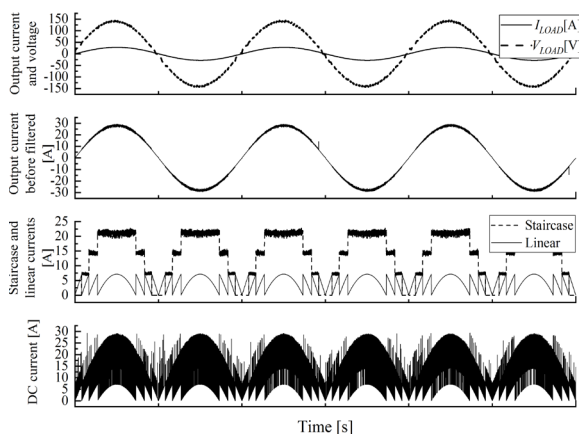

Figure 12. Conventional 9-level CSI

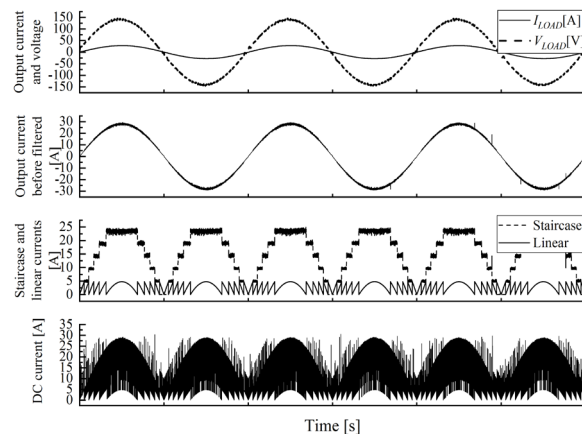

Figure 13. 13-level CSI with 2-1-1 combination

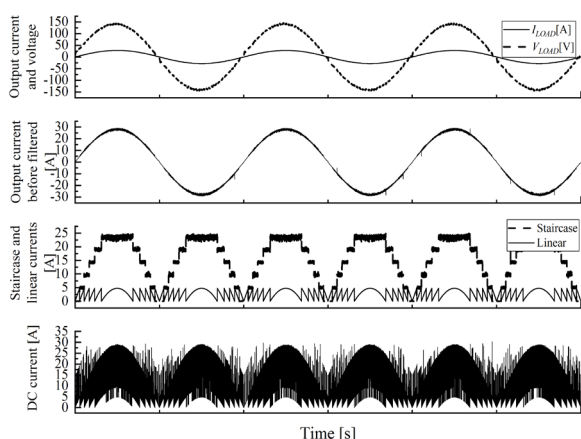

Figure 14.13-level CSI with 1-2-1 combination

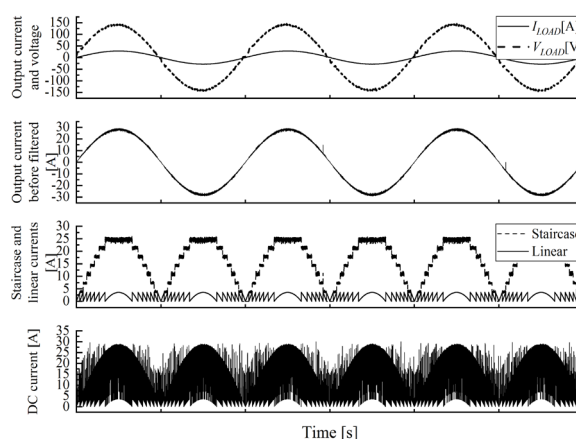

Figure 15.17-level CSI

Table 4. Recorded data of simulation

Parameter	9-level	13-level	13-level	17-level
Layers	2	3	3	4
Stage combination	3-1	2-1-1	1-2-1	1-1-1-1
Load current	20.0 A	20.0 A	20.0 A	20.0 A
Load voltage	100.5 V	100.7 V	100.6 V	100.2 V
DC current	13.0 A	12.5 A	12.5 A	12.1 A
THD-I	0.76 %	0.85 %	0.92 %	0.90 %
THD-V	1.91 %	1.95 %	2.04 %	2.05 %
THD-I before filtering	2.04 %	2.04 %	2.02 %	2.02 %
Efficiency	77.0 %	80.5 %	80.3 %	81.8 %

Table 5. Conventional vs proposed

Parameter	13-level conventional	13-level proposed	17-level conventional	17-level proposed
Layers	2	3	2	4
Stage combination	5-1	2-1-1	7-1	1-1-1-1
Switch count	10	6	14	6
Diode count	15	9	21	9
Inductor count	5	3	7	3
Load current	20.2 A	20.0 A	20.2 A	20.0 A
Load voltage	101.2 V	100.7 V	101.5 V	100.2 V
DC current	12.6 A	12.5 A	12.3 A	12.1 A
THD-I	1.22 %	0.85 %	1.69 %	0.90 %
THD-V	2.44 %	1.95 %	3.28 %	2.05 %
THD-I before filtering	3.20 %	2.04 %	4.59 %	2.02 %
Efficiency	80.9 %	80.5 %	82.9 %	81.8 %

Table 4 shows the comparison among CSI with 3 DC current modules and a linear current compensator, but they have different stage combination configurations. The worst efficiency was presented by 9-level CSI with 3-1 stage combination or 9-level conventional with 77.0 % power efficiency. The best performance was presented by 17-level CSI with 1-1-1-1 stage combination. Despite having highest THD-V with 2.05 %, the 17-level CSI resulted the highest efficiency with 81.8 %.

While table 5 shows the comparison of the corresponding level between conventional method and the proposed one. It is shown the proposed method CSI didn't give better efficiency, but it gave better THD with fewer devices and inductors. With slightly different in efficiency, the proposed method can be considered as a solution for constructing a multilevel CSI with high number of levels.

5. Conclusions

A new technique in generating a pure sinusoidal output current for high number of levels of the multilevel CSI with using fewer switching devices has been presented with simulation results. By arranging the activation of the current modules, the needs of switching devices of the multilevel CSI can be reduced. However, due to linear circuit utilization, the efficiency of multilevel CSI that uses some current modules never reaches 90%, although it gives very good THD results. It is better to apply this method in a very high number of levels with many current modules, so that the linear compensating current is extremely decreased. Moreover, in case of high current rating application, the combination of the conventional and the proposed methods may give a solution to reduce the inductor size for the current modules that applied in the outmost layer. Therefore, the proper selection of the stage combination will determine the final result. In order to verify the simulations, the multilevel CSI that controlled by using the proposed method is currently being investigated in several hardware experimental setups.

Acknowledgment

Eka Rakhman Priandana was supported by Noguchi Laboratory of Shizuoka University and by Research and Innovation in Science and Technology Project (RISET-PRO), Ministry of Research, Technology, and Higher Education of Indonesia. Any opinions, findings, and conclusions expressed in this material are those of the authors, and do not necessarily reflect the views of the funding agencies. Authors also would like to gratitude anonymous reviewers for their very helpful and constructive comments, which improved this manuscript from the original.

6. References

- [1] J Rodriguez, JS Lai, FZ Peng 2002 Multilevel inverter: a survey of topologies, controls, and application *IEEE Trans. on Industrial Electronics* **49(4)** 724-738.
- [2] AK Koshti and MN Rao 2017 A brief review on multilevel inverter topologies *2017 International Conference on Data Management, Analytics and Innovation (ICDMAI)*.
- [3] PP Dash and M Kazerani 2011 A multilevel current-source inverter-based grid-connected photovoltaic system *2011 North American Power Symp.*
- [4] S Yamaguchi, T Noguchi, A Ikegami 2013 Hybrid current-source inverter with high-efficiency characteristic and low-distortion output *IEEJProc. of Annual Conf.* C4-2.
- [5] Suroso and T Noguchi 2010 New H-bridge multilevel current-source PWM inverter with reduced switching device count *Proc. of IEEJ Int. Power Electronics Conf.* 1228-1235.
- [6] T Noguchi, Y Iwata, S Yamaguchi 2017 Pure sinusoidal output current-source inverter using inductor modules *2017 IEEE 12th Int. Conf. on Power Electronics and Drive Systems (PEDS)* 869-874.
- [7] Suroso and T Noguchi 2011 Common-emitter topology of multilevel current-source pulse width modulation inverter with chopper-based dc current sources *IET Power Electronics* **4(7)** 759-766.
- [8] T Noguchi and Suroso 2010 Review of novel multilevel current-source inverters with H-bridge and common-emitter based topologies *IEEE Energy Conversion Congress and Exposition* **5** 4006-4011.
- [9] JH Jeong, GH Kim, BR Min, CH Ahn, GH Cho 1997 A high efficiency class A amplifier accompanied by class D switching amplifier. *PESC97. Record 28th Annual IEEE Power Electronics Specialists Conference. Formerly Power Conditioning Specialists Conference 1970-71. Power Processing and Electronic Specialists Conference 1972.*
- [10] PD Hiscocks 2011 *Analog Circuit Design 2nd Edition* John Wiley and Sons Ltd 358.